



Overview and Identification

The Delta Style room humidity transmitter measures relative humidity (RH) and outputs a 0 to 100% RH on either a 4 to 20mA, 0 to 5V or 0 to 10V signal. It can be ordered with optional temperature sensor and LCD display.

The unit is powered by a wide selection of AC or DC power depending on the signal selection. The optional LCD display can selectively show RH and/or temperature values. The optional temperature sensor can use any 2-wire passive sensor.

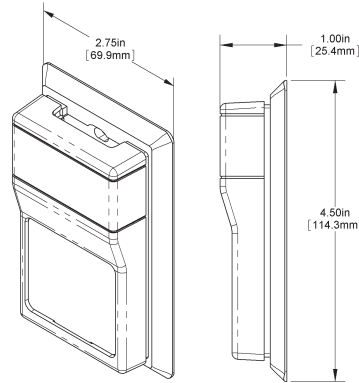

Fig. 1: Delta Style Room Humidity Transmitter without Display

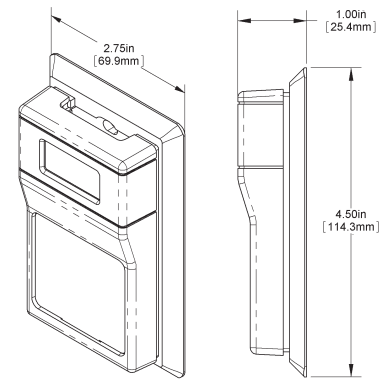

Fig. 2: Delta Style Room Humidity Transmitter with Display

Mounting

LOCATION: Avoid mounting on outside walls or in direct sunlight.

JUNCTION BOX (J-Box), (Fig. 3)

1. Pull the wire through the wall and out of the junction box, leaving about six inches free.
2. Pull the wire through the hole in the base plate.
3. Stuff insulation into box behind the sensor plate and screw the plate firmly to the J-box.
4. Secure the back plate to the box using the #6-32 x 5/8 inch mounting screws provided.
5. Terminate the unit according to the guidelines in the Termination section.
6. Attach cover by latching it to the top of the base, rotating the cover down and snapping it into place.
7. Secure the cover by backing out the lock-down screws using a 1/16" Allen wrench until it is flush with the bottom of the cover.

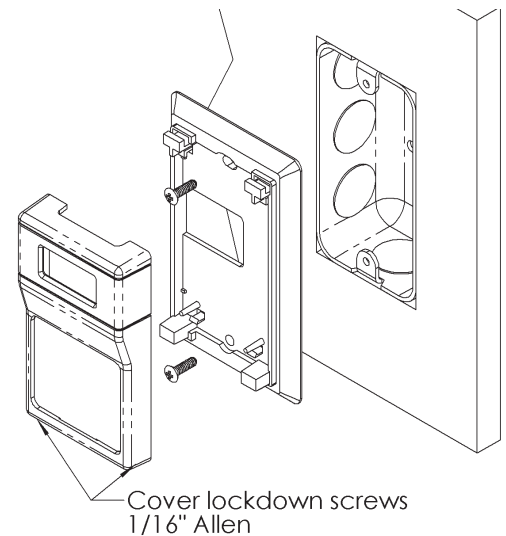

Fig. 3: Delta Style Unit Installation. Mounting hardware is provided for both junction box and drywall installation (junction box installation shown).

DRYWALL MOUNTING (Similar to Fig. 3 but without the J-Box)

1. Place the base plate against the wall where you want to mount the sensor and mark the two mounting holes and the area where the wires will come through the wall.
2. Drill two 3/16" holes in the center of each marked mounting hole. Insert a drywall anchor into each hole.
3. Drill one 1/2" hole in the middle of the marked wiring through hole area.
4. Pull the wire through the wall and out the 1/2" hole, leaving about six inches free.
5. Pull the wire through the hole in the base plate.
6. Stuff insulation into the wall behind the sensor plate and screw the plate firmly to the wall anchors.
7. Secure the base to the drywall anchors using the #6 x 1" mounting screws provided.
8. Terminate the unit according to the guidelines in the Termination section.
9. Attach cover by latching it to the top of the base, rotating the cover down and snapping it into place. Secure the cover by backing out the lock-down screws using a 1/16" Allen wrench until it is flush with the sides of the cover.

Note: In any wall-mount application, the wall temperature and the temperature of the air within the wall cavity can cause erroneous readings. The mixing of room air and air from within the wall cavity can lead to condensation, erroneous readings and sensor failure. To prevent these conditions, BAPI recommends sealing the conduit leading to the junction box with fiberglass insulation.



Termination

BAPI recommends using twisted pair of at least 22AWG and sealant filled connectors for all wire connections. Larger gauge wire may be required for long runs. All wiring must comply with the National Electric Code (NEC) and local codes. Do NOT run this device's wiring in the same conduit as AC power wiring. BAPI's tests show that fluctuating and inaccurate signal levels are possible when AC power wiring is present in the same conduit as the signal lines. BAPI does not recommend wiring the sensor with power applied as accidental arcing may damage the product and will void the warranty.



BAPI recommends wiring the product with power disconnected. Proper supply voltage, polarity and wiring connections are important to a successful installation. Not observing these recommendations may damage the product and void the warranty.

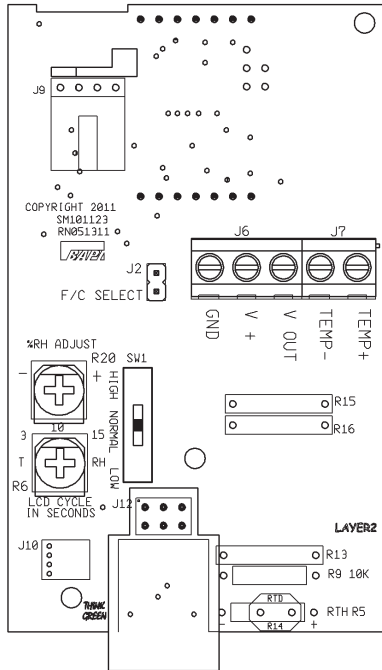

Fig. 4: Circuit Board (shown with optional temperature sensor)

4 to 20mA Humidity Output Termination

TERMINAL FUNCTION

- GND..... 4 to 20mA Loop Humidity Signal (To analog input of controller)
- V+ Main DC Power (See power requirements in specifications)
- V OUT..... Not Used (No termination)
- TEMP +..... Optional Passive Temp. Sensor (No polarity for RTDs or Thermistors) (“+” terminal is the 5 to 30 VDC bias voltage for Semiconductors)
- TEMP - Optional Passive Temp. Sensor (No polarity for RTDs or Thermistors) (“-” terminal is the temperature signal for Semiconductors)

0 to 5VDC or 0 to 10VDC Humidity Output Termination

TERMINAL FUNCTION

- GND..... Ground for Power and Reference for the Humidity Voltage signal
- V+ Main Power (See power requirements in specifications)
- V OUT..... Humidity Voltage Signal Output (0 to 5VDC or 0 to 10 VDC)
- TEMP +..... Optional Passive Temp. Sensor (No polarity for RTDs or Thermistors) (“+” terminal is the 5 to 30 VDC bias voltage for Semiconductors)
- TEMP - Optional Passive Temp. Sensor (No polarity for RTDs or Thermistors) (“-” terminal is the temperature signal for Semiconductors)

- Notes:**
1. Transmitter is common ground (CG) for voltage outputs
 2. “TEMP +” and “TEMP -” terminals are isolated to only the temperature sensor.

Optional Communication Jack Wiring

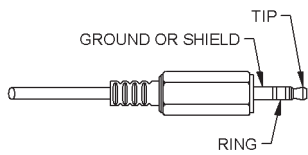
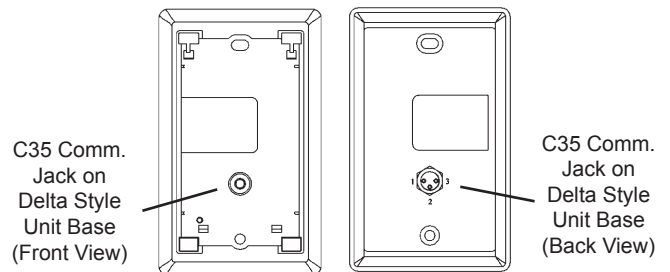

Fig. 5: C35 Comm Jack (3.5mm plug shown for clarity)

C35 Wiring	
	Wire Color
Ground	Black
Tip	White
Ring	Red



Optional Test and Balance Switch (SW1) Operation

- High:** Sets the sensor value to the HIGH temp
- Norm:** The sensor will operate normally
- Low:** Sets the sensor value to the LOW temp

Sensor Type	Low Temp (40° F) Resistance Value	High Temp (105°F) Resistance Value
1000Ω RTD	1.02KΩ (41.20°F)	1.15KΩ (101.5°F)
3000Ω Thermistor	7.87KΩ (39.8°F)	1.5KΩ (106.8°F)
10K-2 Thermistor	30.1KΩ (34.9°F)	4.75Ω (109.1°F)
10K-3 Thermistor	26.7KΩ (35.9°F)	5.11KΩ (108.4°F)
10K-3(11K) Thermistor	7.32KΩ (43.7°F)	3.65Ω (105.2°F)



Delta Style Room Humidity Transmitter with Optional Temp. Sensor BA/#-Hxxx-R

Installation and Operating Instructions

27417_ins_Delta_RH

rev. 10/28/16

°F or °C Indication (for display units only)

The jumper on J2 determines whether the unit will display in Fahrenheit or Celcius. With the jumper "On", the unit displays in Fahrenheit which is the factory default. (See diagrams at right.)

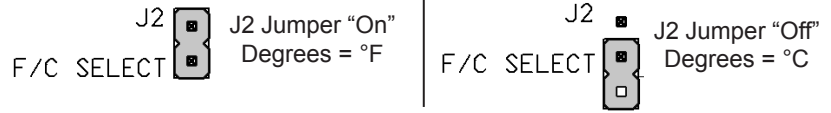

Humidity Reading Offset (for display units only)

The Humidity reading can be offset by $\pm 5\%$ by turning POT R20. (See diagram at right.)



Zero Humidity Offset (centered) is the factory default. Turning clockwise increases the Humidity Offset by up to +5%. Turning counterclockwise decreases the Humidity Offset by up to -5%.

Unit Interval Toggle Rate Between Display of Temperature and Humidity (for display units only)

POT R6 sets the approximate toggle rate between temperature and humidity display of 3 to 15 seconds. POT R6 can also be used to set a constant display of either temperature or humidity. (See diagram at right.)

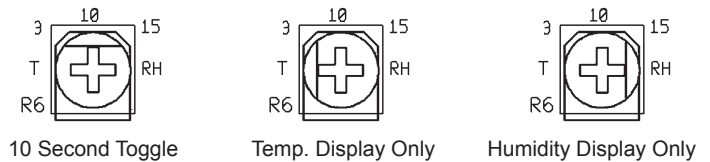

Specifications

Power: Reverse polarity protected.

- 4 to 20 mA Output 10 to 35 VDC, 22mA max
- 0 to 5 VDC Output 10 to 35 VDC, 22mA max
12 to 24 VAC, 0.53VA max
- 0 to 10 VDC Output) 15 to 40 VDC, 6mA max
15 to 28 VAC, 0.14VA max

Note: half wave DC power is recommended. If AC power is used, it must be shielded from the signal wiring.

Sensor:

- Humidity Capacitive w/ temperature compensation & digital output.
%RH resolution is 8 bit
- Optional Temp. Passive Thermistor, RTD or Semiconductor with bias of 5 to 30VDC

Filter: None

- RH Accuracy:** RH Sensor chip
- 200 $\pm 2\%$, from 10% to 90%RH @77°F
- 200 $\pm 3\%$, from <10% to >90%RH @77°F
- 300 $\pm 3\%$, from 0% to 100%RH @77°F
- Resolution RH sensor 0.4%

Temp Display Accuracy: Temperature Chip only

- Temperature $\pm 0.6^\circ\text{C}$ @25°C
- Resolution Temp sensor 0.2°

Optional Temp Sensor Accuracy: Passive 2 wire only

- Thermistor* (std) $\pm 0.36^\circ\text{F}$, ($\pm 0.2^\circ\text{C}$)
(High) $\pm 0.18^\circ\text{F}$, ($\pm 0.1^\circ\text{C}$), [XP] option
- RTD Platinum (PT), 3.85 $\Omega/^\circ\text{C}$ for 1K Ω RTD
Platinum (PT), 0.385 $\Omega/^\circ\text{C}$ for 100 Ω RTD
Nickel (Ni), 2.95 $\Omega/^\circ\text{F}$ for the JCI RTD
- Solid State AD592, bias 5-30VDC

Output: Updated every 2 seconds

- RH (0 to 100%) 4 to 20mA, 0 to 5VDC or 0 to 10VDC
- Temperature Passive Resistance or Semiconductor

Impedance:

- Current 700 Ω @ 24VDC minimum
- Voltage 10K Ω maximum

Terminals:

Cage clamp, 16 to 22 AWG

Wiring:

2 to 6 pair depending on options

Mounting:

Standard 2"x4" J-box or drywall, screws provided

Field Humidity Calibration Offset: (Factory calibrated)

- %RH Adj. Potentiometer, $\pm 5\%$

Enclosure Material: ABS Plastic, UL94V-HB

Optional Display: 3.5 digit LCD

- Dimensions 0.5"H x 1.1"W, Digits .4"H
(13.34 x 29.21mm), (Digits 10.29mm H)
- Range 0 to 100%, -58 to 199.5°F (-50 to 150°C), factory set
- Span 0 to 100%, 32 to 122°F (0 to 50°C), factory set
- Resolution 0.5%RH or 0.5°F or °C
- Units °F or °C, Board jumper (J2)
- Update Every 2 seconds, factory set
- Alternating Temp/RH, adjustable 3-15 seconds or fixed temperature or humidity
- Power up 0% RH & 0.0° at power up for OK
Then reads value after 2 seconds
- Fault RH 100% or Temp 0% for sensor fault after 500 sec.

Optional Comm. Jack:

- C35 3.5mm Phono jack

Optional Test & Balance Switch:

- TB 3 position switch High/Normal/Low
Passive temp sensor output only

Environmental Ambient Range:

- Temp 32° to 122°F, (0° to 50°C)
- Humidity 5% to 95% RH (Non-Condensing)

Agency:

RoHS, UL94V-HB,
CE* (EN50081-1:1998, EN61000-6-2)

*All passive thermistors 20K Ω and smaller are CE Compliant

Specifications subject to change without notice.



Commissioning

- 1 Mount and wire the transmitter per the instructions above (Mounting and Termination)
- 2 Read the optional passive sensor value at the controller. It should show the room temperature per the accuracy spec above.
- 3 Test and Balance option is described in the "Configuration Adjustments" above and will only affect the optional passive temperature sensor [TEMP +] and [TEMP -] output. As you switch from High to Low and to Norm you should see the resistance change per the table in section "Optional Test & Balance Switch".
- 4 Remove power from the unit and disconnect the [TEMP +] wire. Measure the resistance across the [TEMP +] and [TEMP -] terminals for units with a thermistor or RTD temp sensor. (A solid state sensor must be read from a controller.) The resistance of the thermistor or RTD should correlate with the temperature in the room. Temp/resistance tables for thermistors and RTDs are available in the "Resource Library" on the BAPI website at "www.bapihvac.com". Reconnect the wires when finished.
- 5 Power up the transmitter and read the output values after 2 seconds, per the instructions below.
 - **Voltage Output:** Read the voltage output with a volt meter from [GND] to [V OUT]. Read the RH voltage in proportion to the RH sensor. See the Humidity Formula chart below.
 - **Current Output;** Read the current output with a current meter in series with the [GND] terminal and field wire. Read the RH current (between 4-20mA) in proportion to the RH sensor. See the Humidity Formula chart below.
- 6 If this is a display transmitter then follow the "Configuration Adjustments" to set the °F or °C indication and unit interval toggle rate.
 - **°F or °C Indication:** Set the display units to °F or °C as needed with J2 jumper
 - **Unit Interval Toggle Rate:** Set the temp. and humidity display rotation with R6.

Output	Humidity Formula
4 to 20mA	%RH =(mA-4)/0.16
0 to 5VDC	%RH = V/0.05
0 to 10VDC	%RH = V/0.1

Diagnostics

Problems:

Possible Solutions:

General Troubleshooting

- Determine that the input is set up correctly in the controller and building automation software.
- Check wiring at the sensor and controller for proper connections. Also, check for corrosion at either the controller or the sensor. Clean off the corrosion, re-strip the interconnecting wire and reapply the connection. In extreme cases, replace the controller, interconnecting wire and/or sensor.
- Label the interconnecting sensor wires then disconnect them at the sensor end and controller end. With the wires disconnected at both ends, measure the resistance from wire-to-wire with a multi-meter. The meter should read greater than 10 Meg-ohms, open or OL depending on the meter. Now short the interconnecting wires at one end. Go to the other end and measure the resistance from wire-to-wire with a multi-meter. The meter should read less than 10 ohms (22 gauge or larger, 250 feet or less). If either test fails, replace the wire.

Incorrect Humidity

- Check power supply/controller voltage supply. Also, disconnect sensor and check power wires for proper voltage (see specifications).
- Check all controller software parameters (V/I/Ω).
- If available, check the sensor against a calibrated instrument such as a hygrometer.
- Determine if the sensor is exposed to an external environment different from the room (conduit draft, diffuser above, radiation below, etc.).
- Adjust the offset POT R20 to your reference value (±5%). (See "Humidity Reading Offset" section)

Incorrect Temperature

- Determine that the sensor's wires are properly connected to the correct controller input terminals.
- Check the wires at the sensor and controller for proper connections.
- For units with a thermistor or RTD temperature sensor, measure the physical temperature at the sensor's location using an accurate standard. Disconnect the temperature sensor's wire terminals [TEMP+] and [TEMP-] and measure the sensor's resistance across the terminals with an ohmmeter. Compare the sensor's resistance to the appropriate temp/resistance table in the "Resource Library" of the BAPI website (www.bapihvac.com). If the measured resistance varies from the temperature table by more than 5%, call BAPI technical support.
- Determine if the sensor is exposed to an external environment different from the room (conduit draft, diffuser above, radiation below)

Faulty %RH/Temperature Sensor Chip

- On power up, a normally-operating unit will display 0%RH and 0.0 °F or °C for 2 seconds. After 2 seconds, the unit will begin to display the actual %RH and temperature. If there is no display reading after 500 seconds (0%RH and 0.0°F or °C), then the unit will default to a %RH reading of 100% and a temp reading of 0.0°, indicating a bad sensor. Replace the unit.